

# *TECHNICAL INFORMATION*

---

**CITIZEN QUARTZ  
Cal. No. 8970**

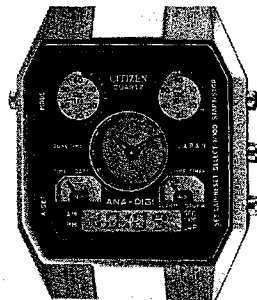

 **CITIZEN**

## 51. OUTLINE

We have developed this new product by changing the construction of the dial and the layout of the face, based on the module of the conventional CAL. 8940, which has added to the uniqueness of the watch. This new product improves on the fine functional features of the CAL. 8943.

## 52. SPECIFICATIONS

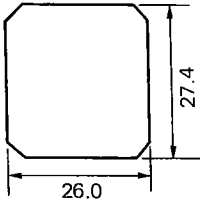
Caliber No.		8970-02
Type		Combination quartz watch
Size of module (mm)		 <p>Thickness: 4.5 5.1 (including power cell part)</p>
Accuracy		±15 sec./month at normal temperatures
Oscillation		32,768Hz
Integrated circuit		C/MOS-LSI (1 unit)
Effective temp. range		0°C ~ +60°C (32°F ~ 140°F)
Converter		Bipolar step motor
Adjustment of time rate		By trimmer condenser
Measurement of time rate		2 seconds
Digital display	Normal time	Hour, minute, second (60/10 sec. circle segment)
	Calendar	Day, date, (Automatic)
	Alarm	Hour, minute, AM/PM, (12/24 hour is interlocked with the time mode.)
	Chime	ON/OFF
	Timer	Hour, minute, sec. (60/10 sec. circle segment) Up to 11 hours 59 minutes 59 seconds
	Stopwatch	Minutes, seconds, 1/100 second (by switching display), 60 minutes display
Analog display		Hour, minute (20 sec. unit hand motion)
Additional functions		Power cell life indicator Instant manual return Automatic calendar (1980 ~ 2019) Alarm monitor
Power cell	Parts No.	280-30
	Cell code	SR1120W (Ag <sub>2</sub> O/KOH)
	Size (mm)	11.6φ x 2.05 <sup>t</sup>
	Voltage	1.55V
	Capacity	55mAH
	Life time	Approximately 3 years (60 sec. Alarm/Day, 24 hourly chimes, Timer/4 days)
Electrical consumption		Max. 2μA (Module consumption)
Coil resistance		1.2kΩ ~ 1.6kΩ
Remarks		

### 53. HANDLING INSTRUCTIONS

#### 3-1. Nomenclature and functions of push-buttons

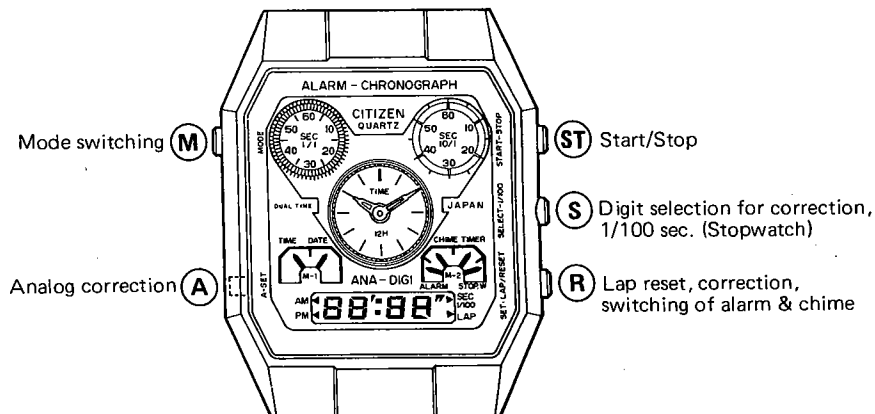

#### 3-2. Mode switching

- Each time the (M) button is pressed, the mode is changed in the order listed below.
- The "O" marks indicate the flashing parts.

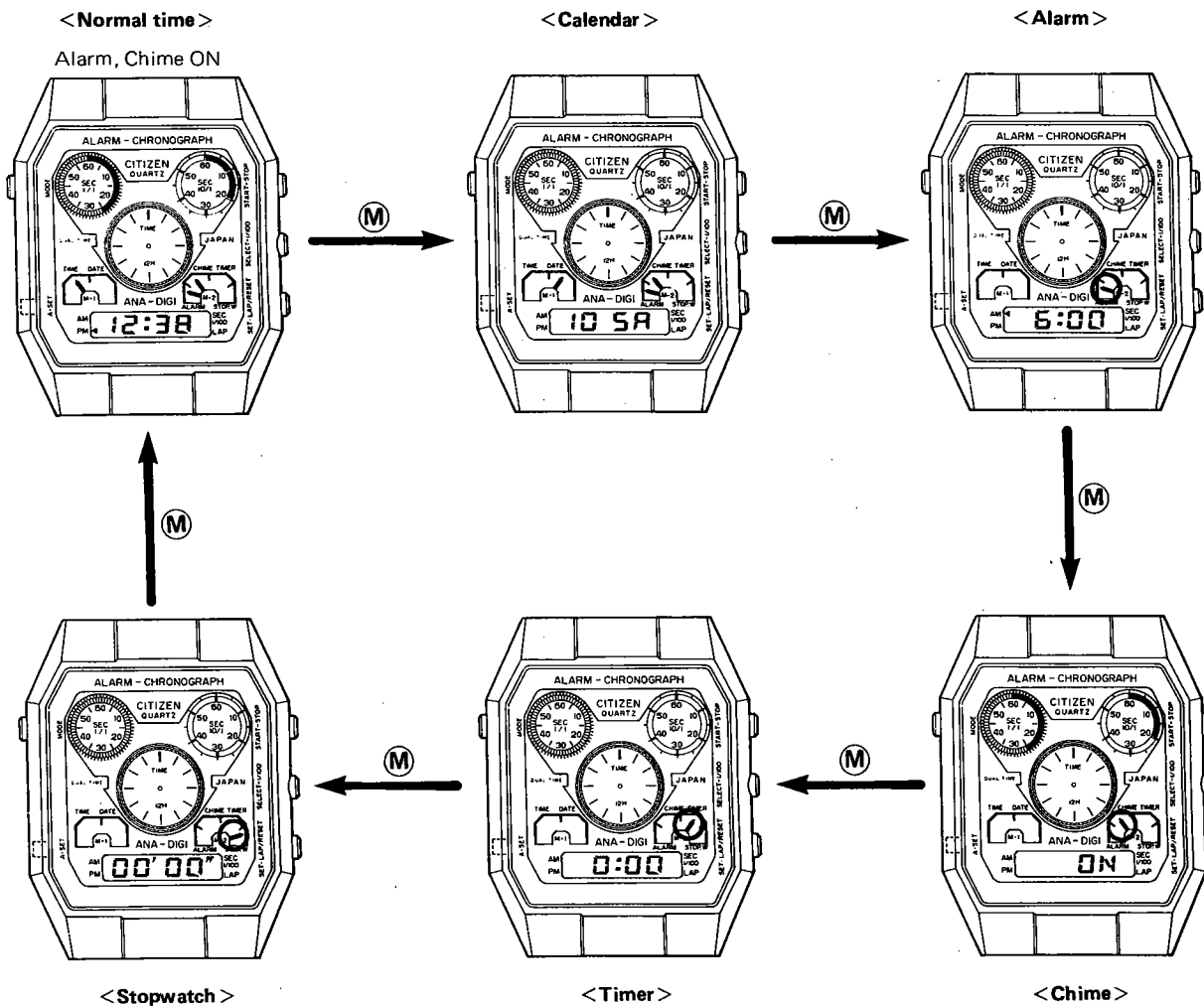

### 3-3. Time correction

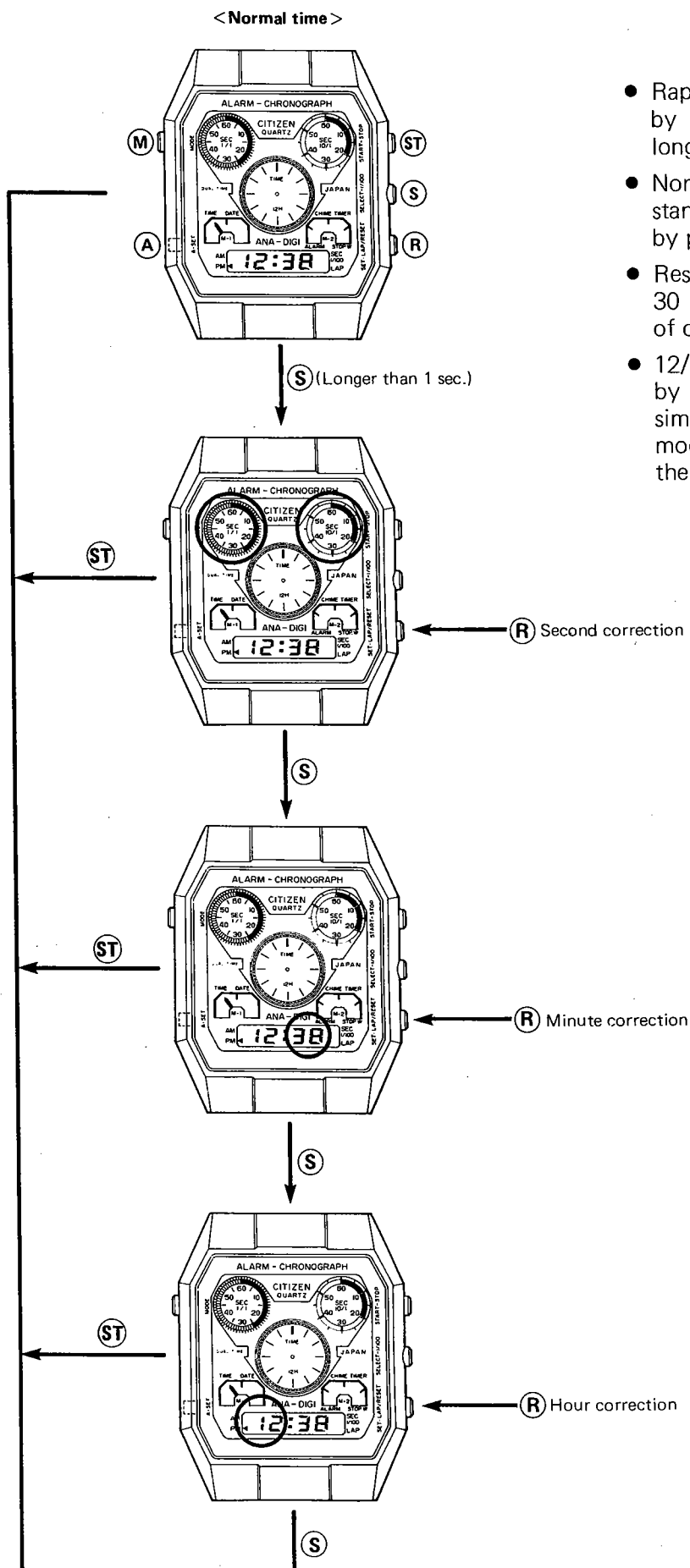

- Rapid time correction is performed by pressing the button 1 second or longer.
- Normal time mode is obtained instantly from any corrected condition by pressing the (ST) button.
- Resetting the second to zero within 30 ~ 59 seconds causes the addition of one minute.
- 12/24 hour switching is possible by pressing the (R) and (ST) buttons simultaneously in the normal time mode. When the buttons are pressed, the sound monitor will sound.

### 3-4. Calendar correction

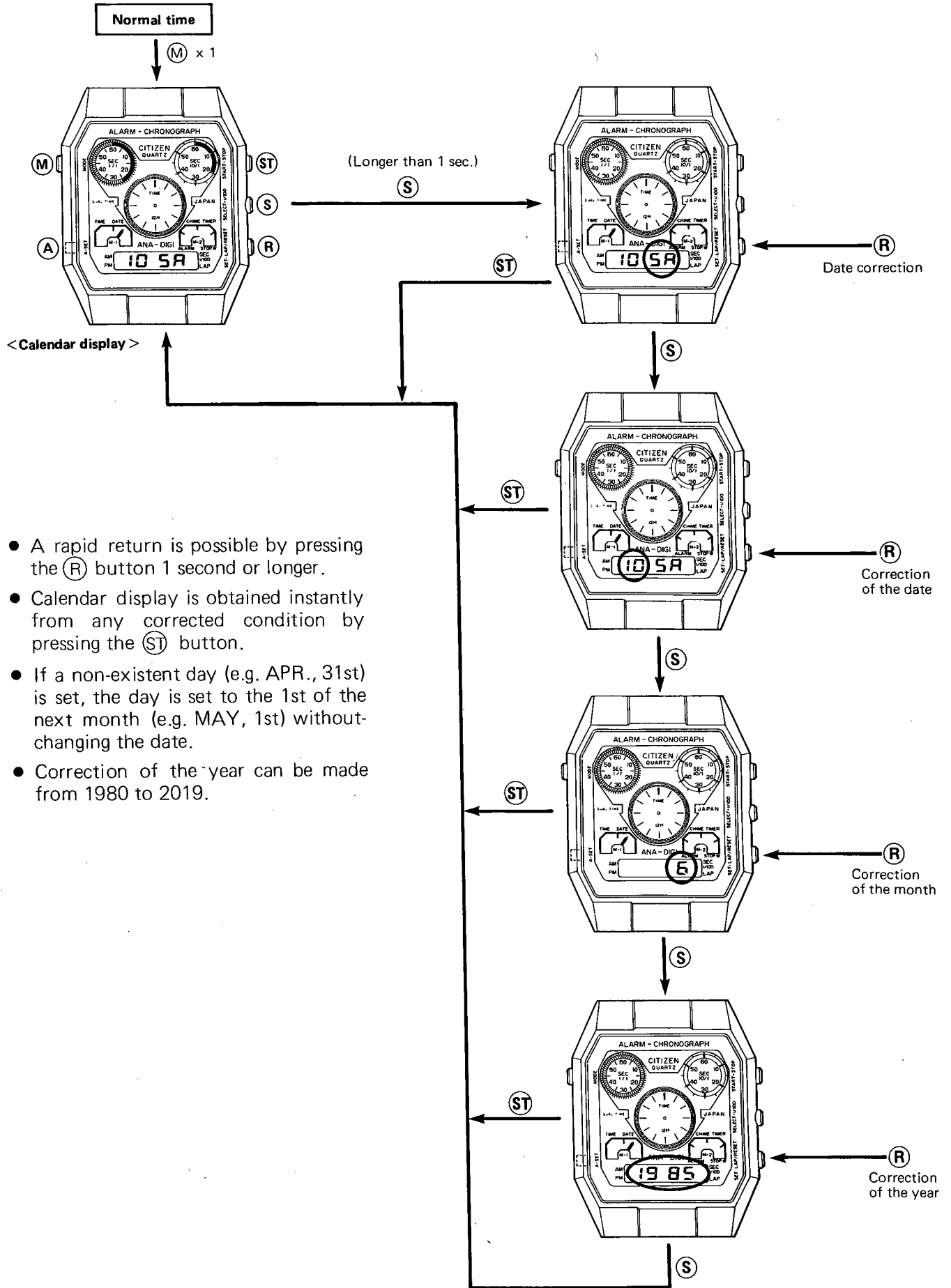

- A rapid return is possible by pressing the (R) button 1 second or longer.
- Calendar display is obtained instantly from any corrected condition by pressing the (ST) button.
- If a non-existent day (e.g. APR., 31st) is set, the day is set to the 1st of the next month (e.g. MAY, 1st) without changing the date.
- Correction of the year can be made from 1980 to 2019.

### 3-5. Correction of the alarm

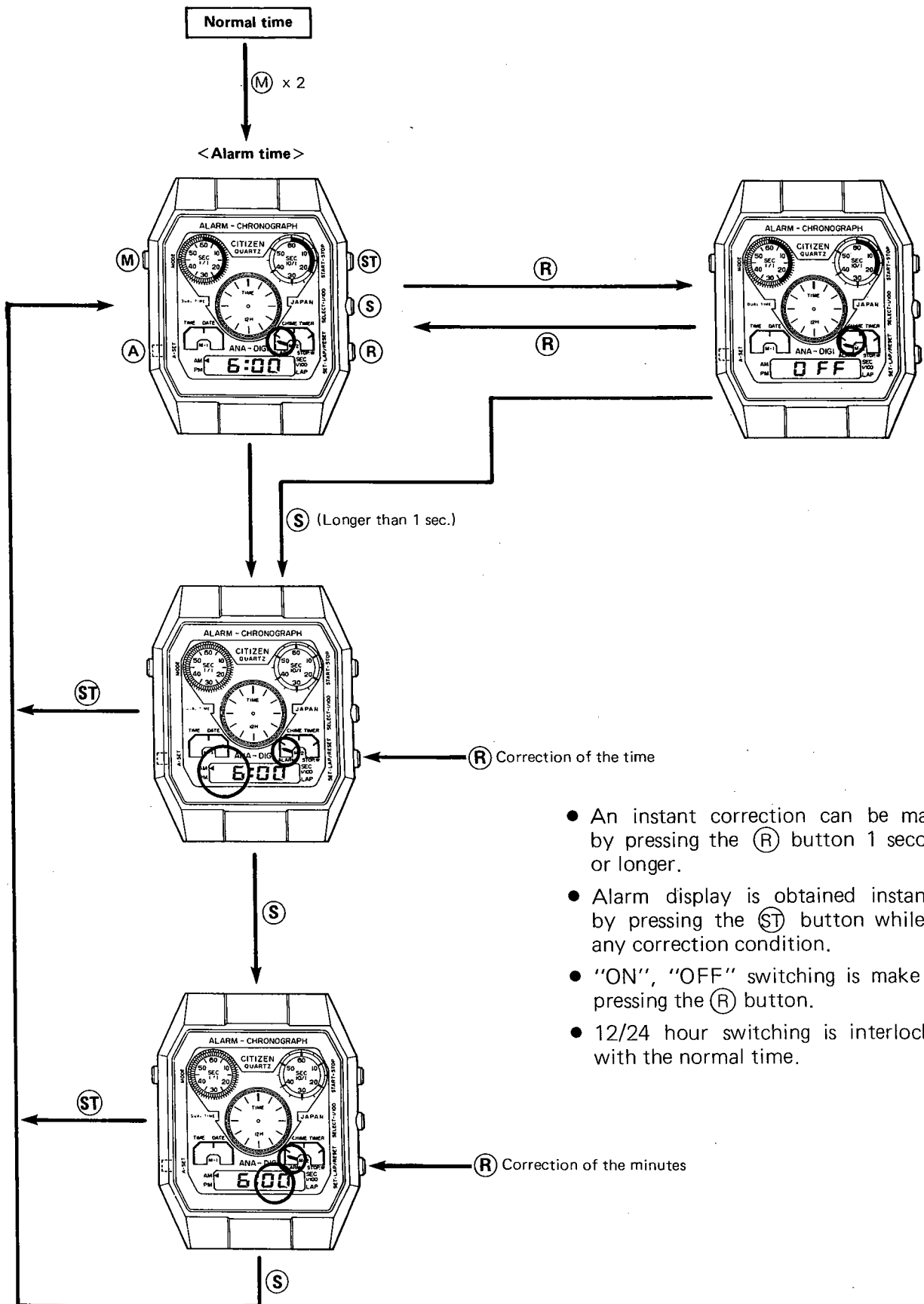

- An instant correction can be made by pressing the (R) button 1 second or longer.
- Alarm display is obtained instantly by pressing the (ST) button while in any correction condition.
- "ON", "OFF" switching is made by pressing the (R) button.
- 12/24 hour switching is interlocked with the normal time.

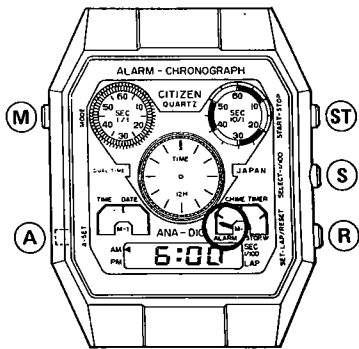

- The alarm rings for 1 minute at the time set along with the flashing of the circled segment. The sounding of alarm can be stopped by pressing any of the push-buttons pictured on the left. (The flashing will also occur when the sound monitor function or when the pre-set time is reached).

### 3-6. Correction of the chime

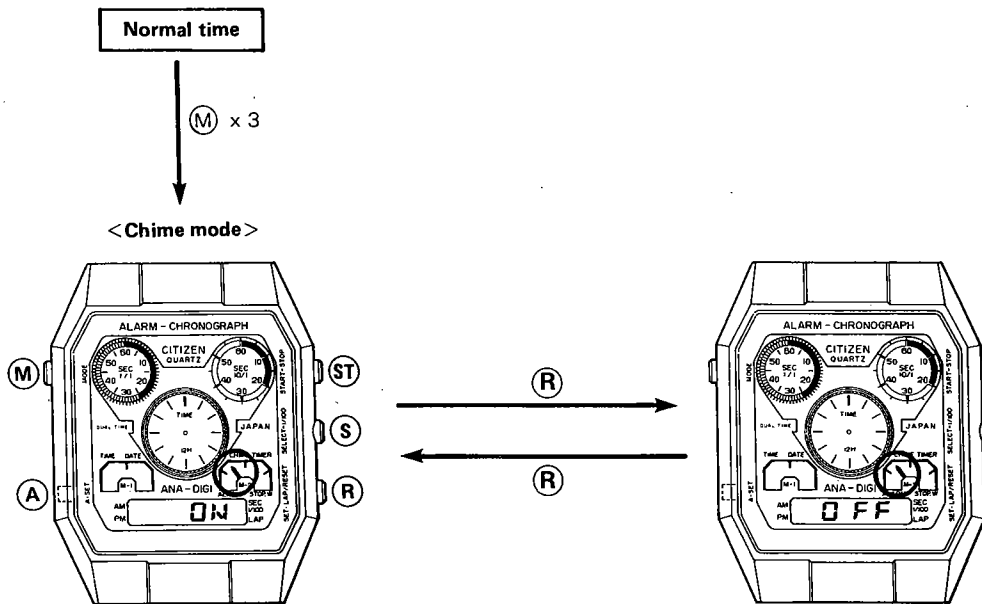

- "ON", "OFF" switching is made by pressing the (R) button.
- In the "ON" condition, the alarm sounds twice on the hour.

### 3-7. Operation of the timer

#### 1) Time setting

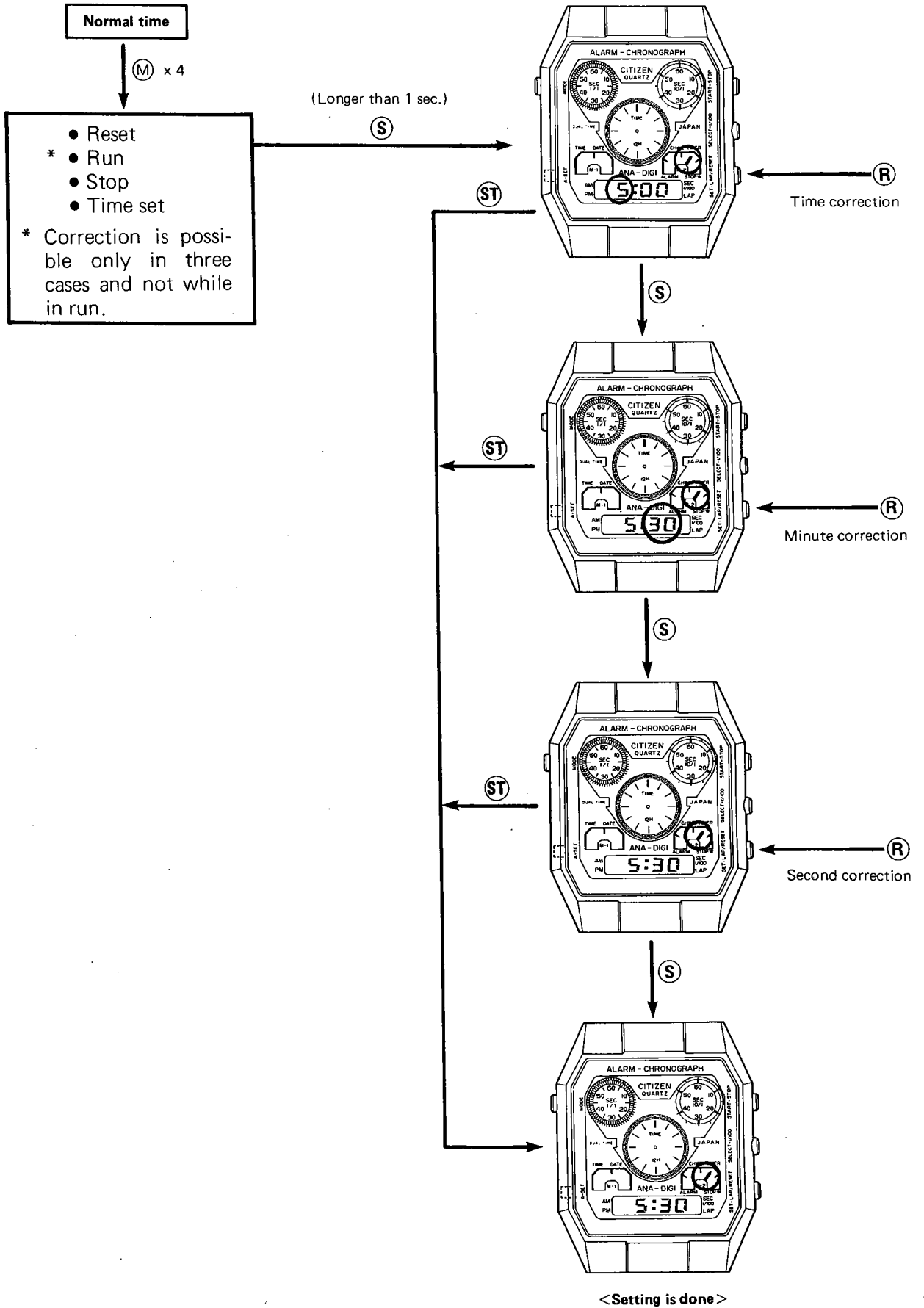



## 2) Operation of buttons

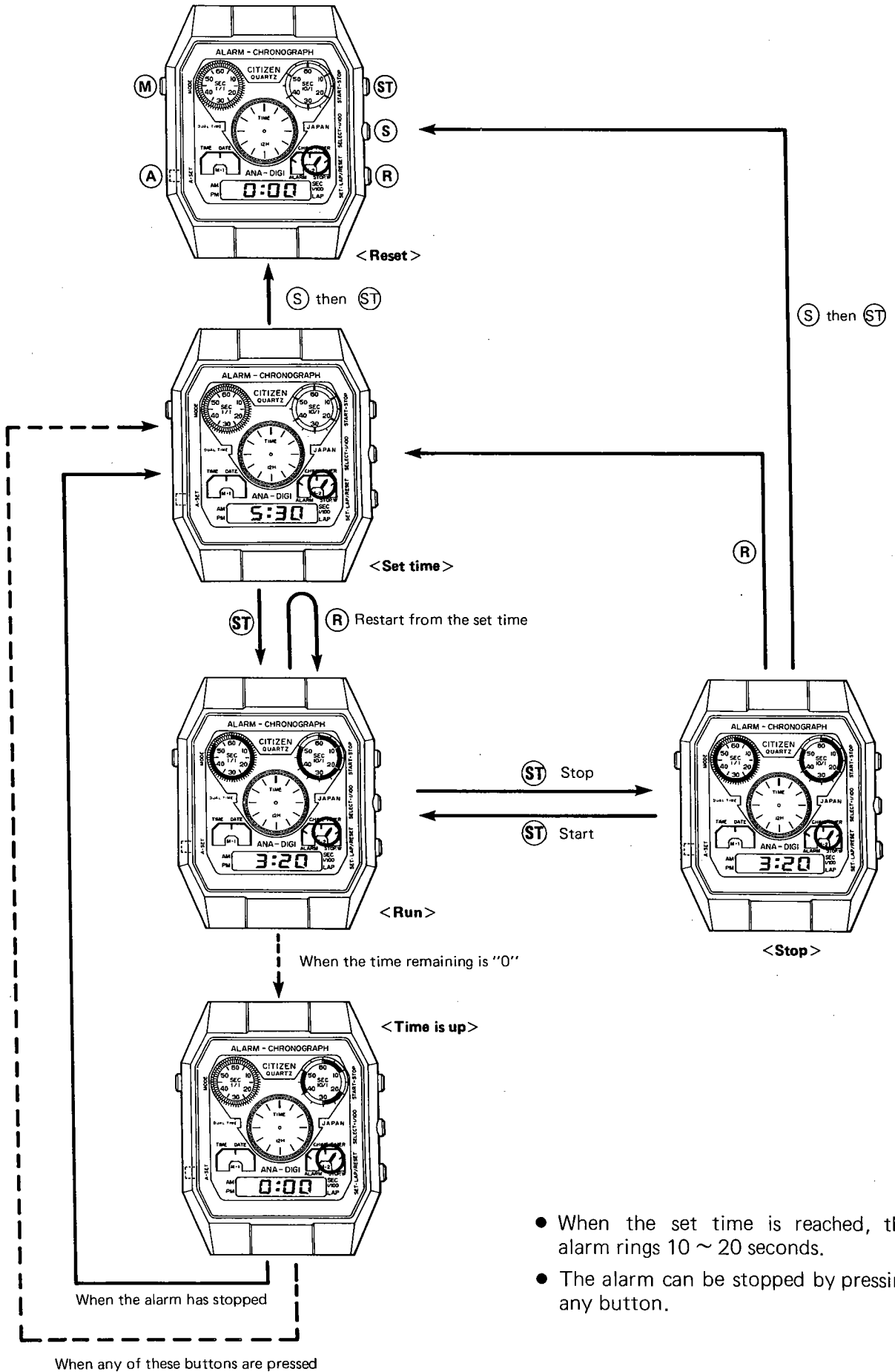

- When the set time is reached, the alarm rings 10 ~ 20 seconds.
- The alarm can be stopped by pressing any button.

### 3-8. Stopwatch operation

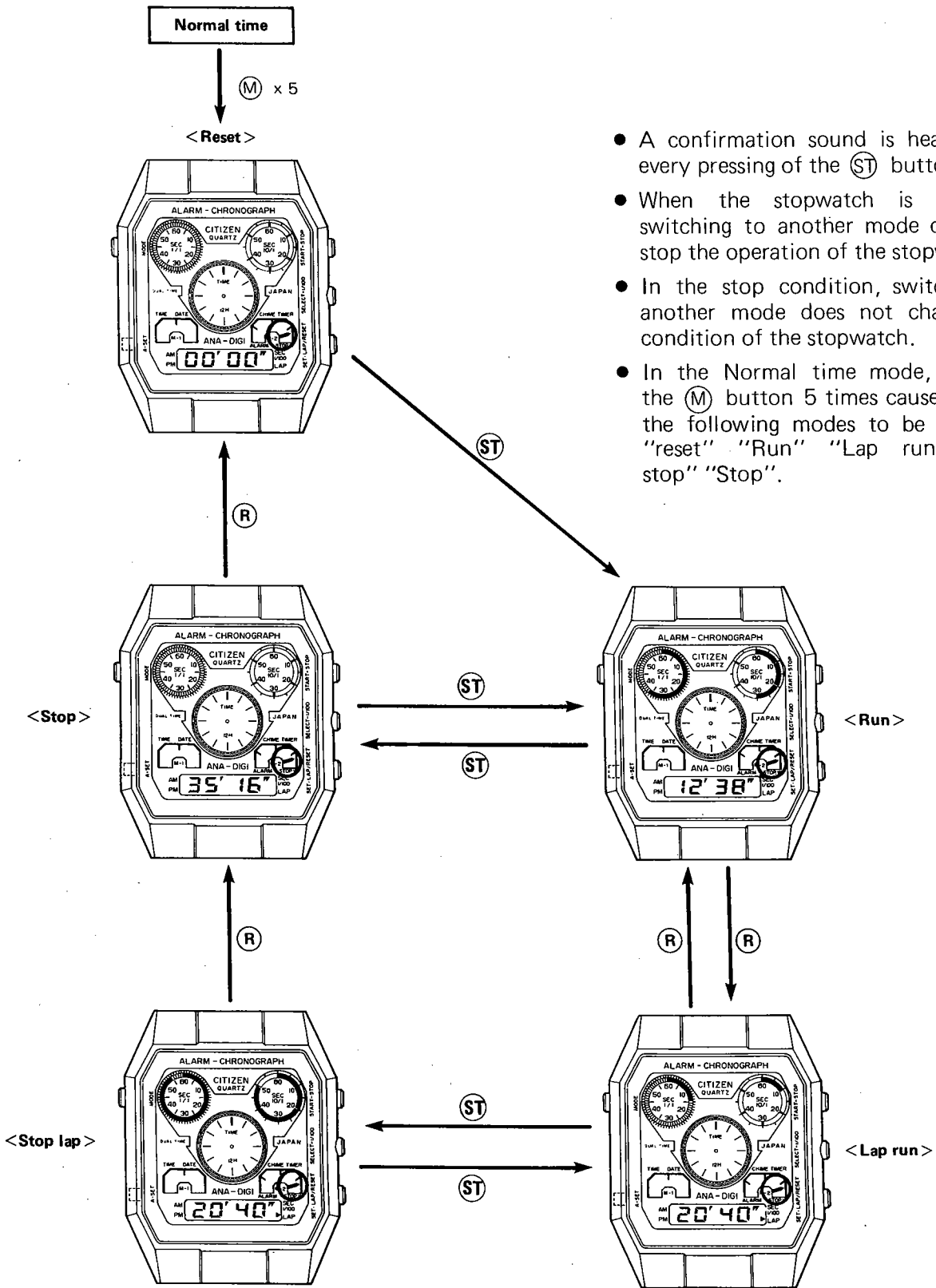

- A confirmation sound is heard with every pressing of the **ST** button.
- When the stopwatch is running, switching to another mode does not stop the operation of the stopwatch.
- In the stop condition, switching to another mode does not change the condition of the stopwatch.
- In the Normal time mode, pressing the **M** button 5 times causes one of the following modes to be selected, "reset" "Run" "Lap run" "Lap stop" "Stop".

- In the run, lap run, stop and lap stop modes, pressing the  $\text{S}$  button switches the minute, second display to the 1/100 second display as long as the  $\text{S}$  button is pressed.

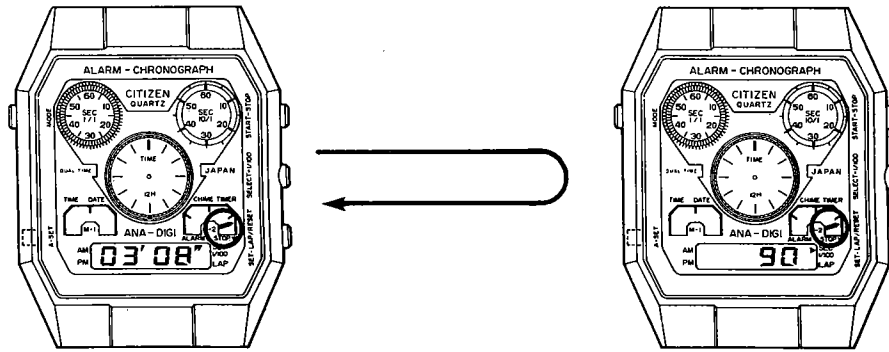

<3 min. 8 sec. 90>

- When the stopwatch mode is used, the circle segment shows the following displays at intervals of 1 second.

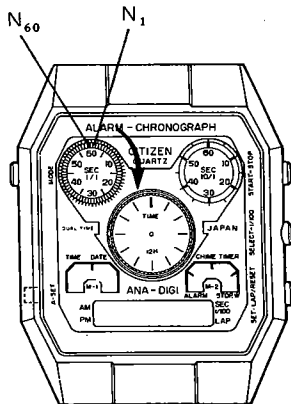

- 1/100 sec. ~ 60/100 sec. Each 1/100 sec. mark lights as the timer functions.
- 60/100 sec. ~ 70/100 sec. The entire N1 ~ N60 segment lights.
- 80/100 sec. ~ 100/100 sec. The entire N1 ~ N60 segment switches off.

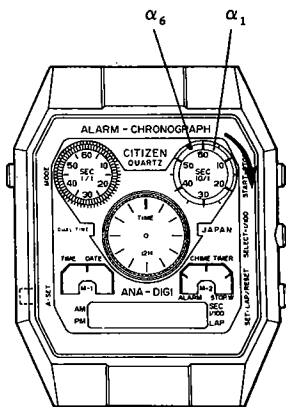

The following displays are interlocked with the 1 second circle segment.

- 1/100 sec. ~ 9/100 sec. The entire segment switches off.
- 10/100 sec. ~ 19/100 sec. Lights up to  $\alpha_1$ .
- 20/100 sec. ~ 29/100 sec. Lights up to  $\alpha_2$ .
- 30/100 sec. ~ 39/100 sec. Lights up to  $\alpha_3$ .
- 40/100 sec. ~ 49/100 sec. Lights up to  $\alpha_4$ .
- 50/100 sec. ~ 59/100 sec. Lights up to  $\alpha_5$ .
- 60/100 sec. ~ 79/100 sec. Lights up to  $\alpha_6$ .
- 80/100 sec. ~ 100/100 sec. The entire segment lights.
- During stop or lap stop, the cumulative counting lights stop to indicate the time; ON or OFF.

### 3-9. Analog time correction

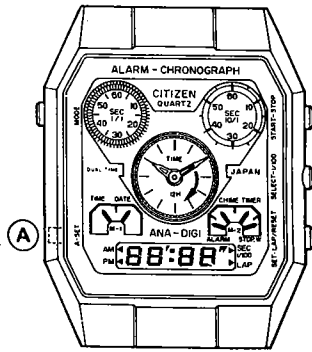

- This watch can be used as a dual watch, since the digital and analog sections can be set separately.
- Correction mode can be obtained by pressing the (A) button in any display mode. However, when the alarm is ringing, the first time the (A) button is pressed, the alarm will stop.
- When the (A) button is pressed once, the Second hand advances 20 seconds. Rapid setting is possible by pressing the (A) button for one second or longer.
- The Correction can be made only in the clockwise direction.

- Setting the analog and digital watch for the same time.
    - Set the digital watch first, then set the analog watch to correspond to the digital time.
- <Example> Setting the analog minute hand to the digital time 00 O'clock, 15 minutes, N seconds.

Digital minutes	Digital seconds	Method for setting the analog minute hand
15	$0 \leq N < 20$	Set the hand to the 15 minute mark
	$20 \leq N < 40$	Set the hand to the 15 minute mark, then press the button once.
	$40 \leq N < 59$	Set the hand to the 15 minute mark, then push the button twice.

#### <Synchronization of seconds>

Synchronization of the digital second function causes a 0-Second-resetting of the analog watch.

This function is used for the speed up or slow down of the watch.

<Example> Changing the analog and digital watch during the 0-Second resetting at N seconds.

Time before the 0-Second resetting	Time after the 0-Second resetting			
	Digital second	Digital minute	Analog minute	
$0 \leq N < 29$	00	Unchanged	Waiting for the N sec. count	*1
$30 \leq N < 39$	00	Adding 1 min.	+2	*2
$40 \leq N < 59$	00	Adding 1 min.	+1	

\*1 Analog correction while waiting for the count causes the cancellation of the waiting.

\*2 The movement of the second level is in 20 seconds units so that one operation will result in a 20 second change. Therefore, the 0-Second resetting between 30 seconds and 39 seconds requires this operation to be performed twice.

## 54. NOTES ON ASSEMBLY/DISASSEMBLY

Items	Contents
<ul style="list-style-type: none"> <li>● Assembly of hands</li> </ul>	<div data-bbox="711 344 1390 548" data-label="Image"> </div> <ul style="list-style-type: none"> <li>● Assembly            Assembly of the hands must be done before installation of the LC display panel, since, the position of the hand should be lower than the LC display panel in the unit.            However, if the hand connector is used, as shown in the diagram, it is possible to assemble the hand after installation of the LC display.</li> <li>● Disassembly            The bow shaped hand remover may caused damage to the LC display panel. Therefore, use a flat pliers and on a suitable tool.</li> </ul>
<ul style="list-style-type: none"> <li>● Assembly of circuit unit supporter and power cell strap.</li> </ul>	<div data-bbox="813 995 1268 1304" data-label="Image"> </div> <ul style="list-style-type: none"> <li>● Make sure that the circled parts are securely assembled when assembling the circuit unit supporter and the power cell strap.</li> </ul>
<ul style="list-style-type: none"> <li>● Assembly of reflecting plate and LC display panel connection rubber.</li> </ul>	<ul style="list-style-type: none"> <li>● The reflecting plate and the LC display panel connection rubber are non-directional.</li> </ul>

## 95. ASSEMBLY/DISASSEMBLY OF MODULE

Disassembling procedure : ① → ⑩  
Assembling procedure : ⑩ → ①

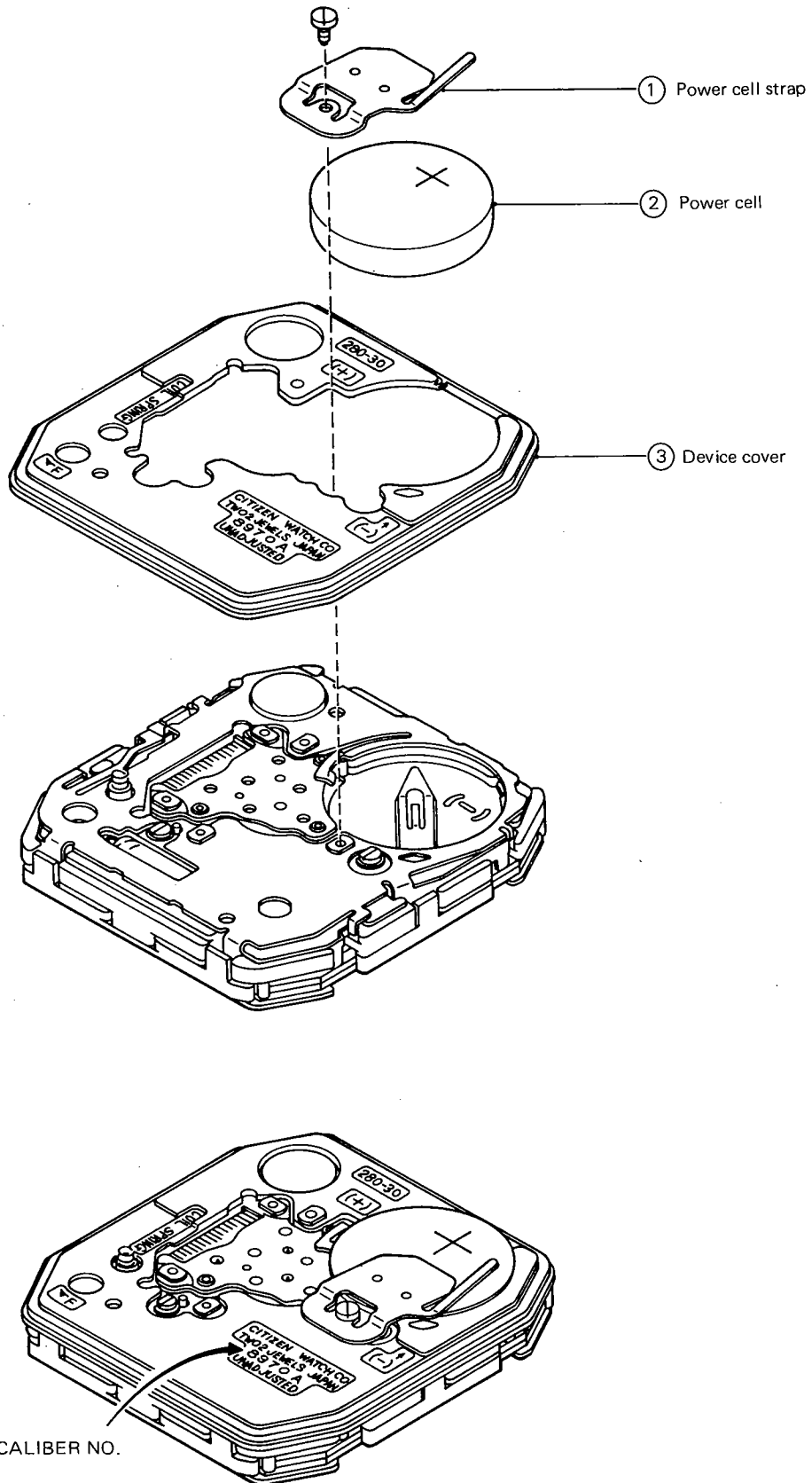

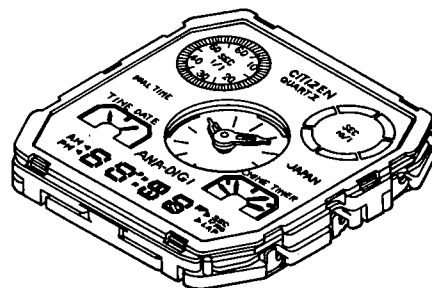
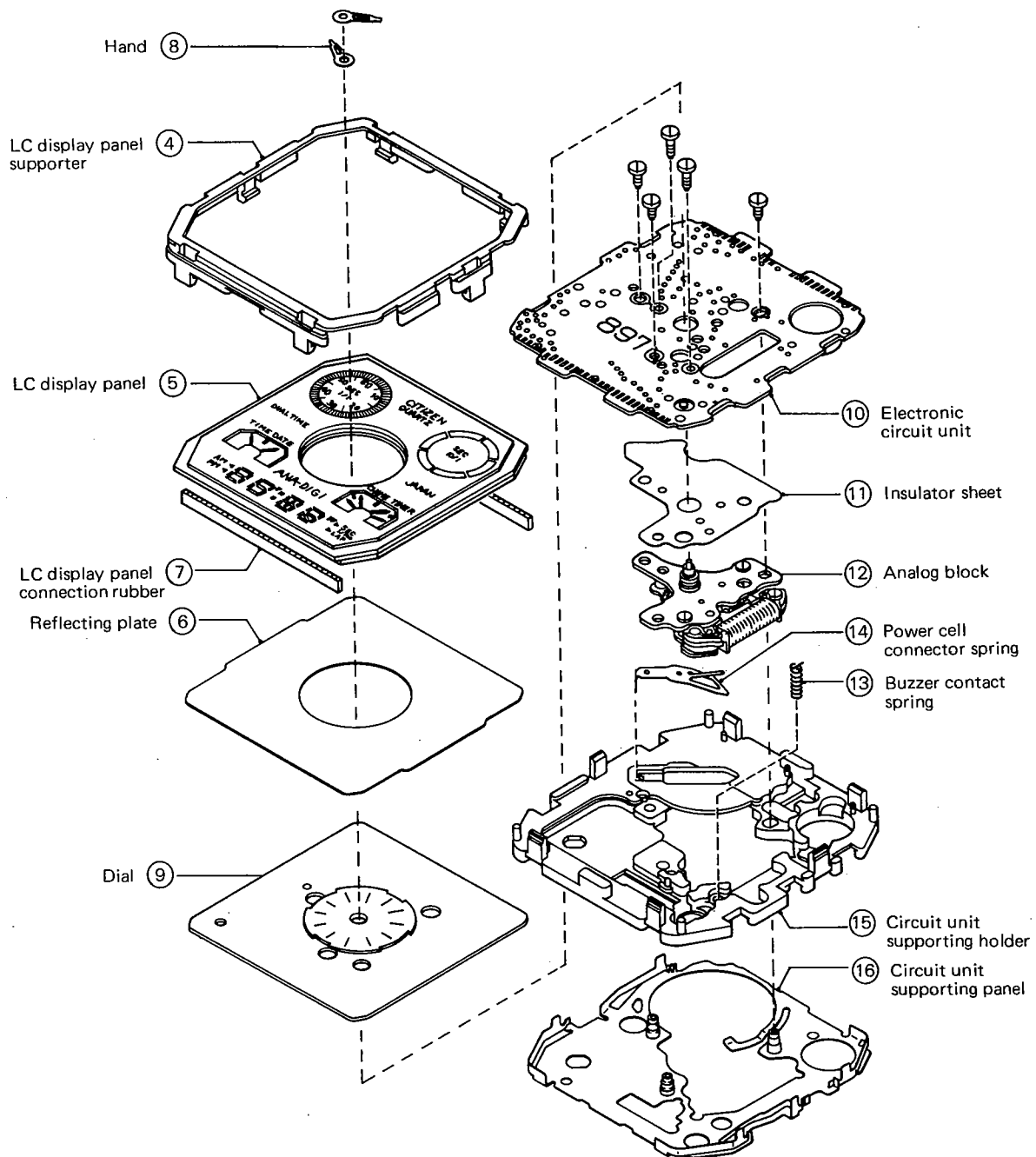

Assembly/Disassembly of analog unit and lubrication

Acceptable Lubrication Brands

- Ⓐ Sinta A Lube
- Ⓑ Sinta F Lube

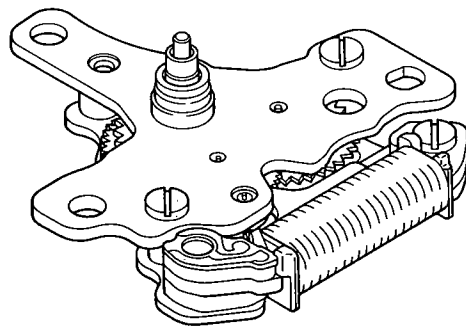
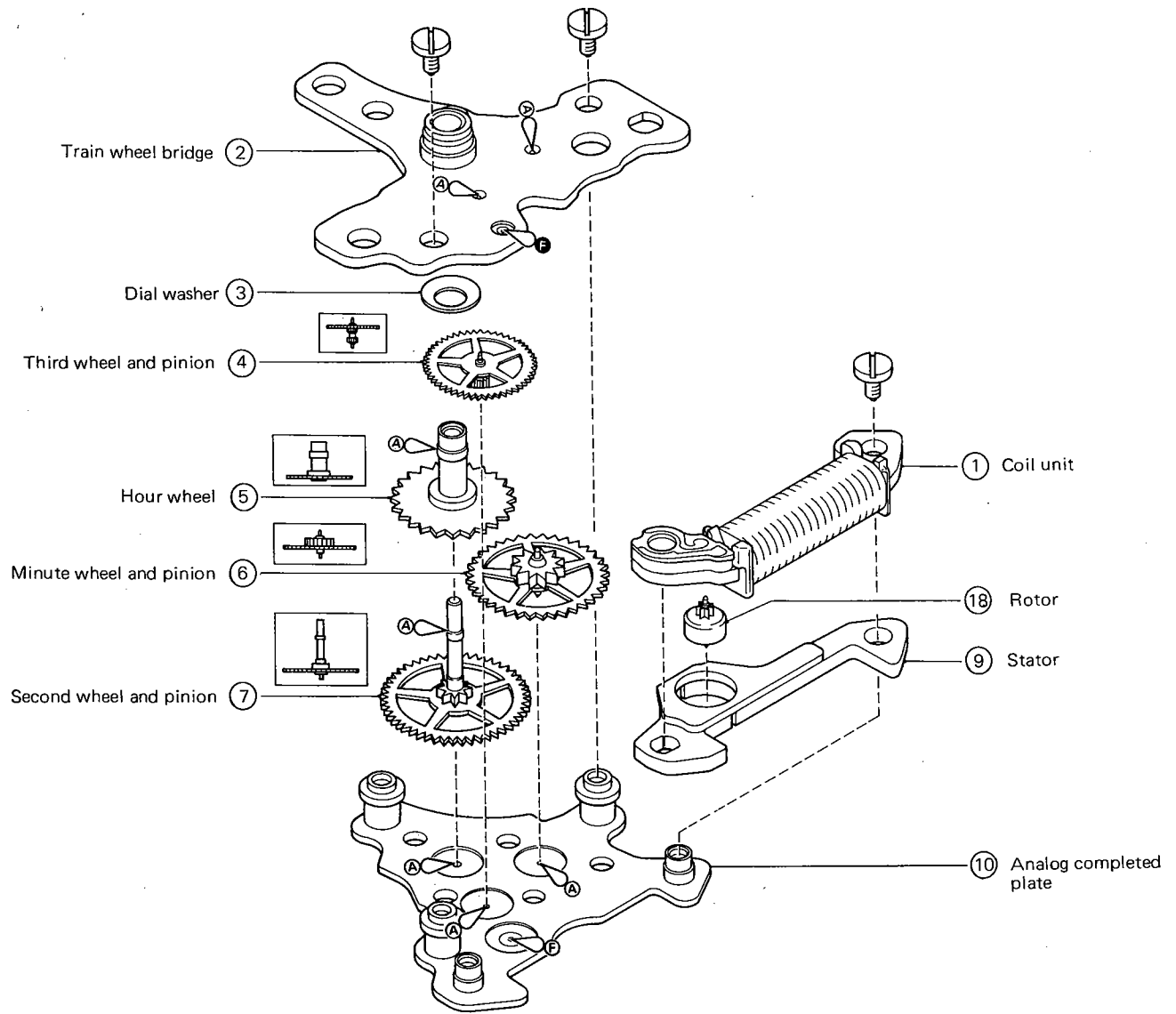

< Analog block >

\* Movement holder for the CAL. 8940 can be used for this caliber.



# I. TROUBLESHOOTING AND ADJUSTMENT

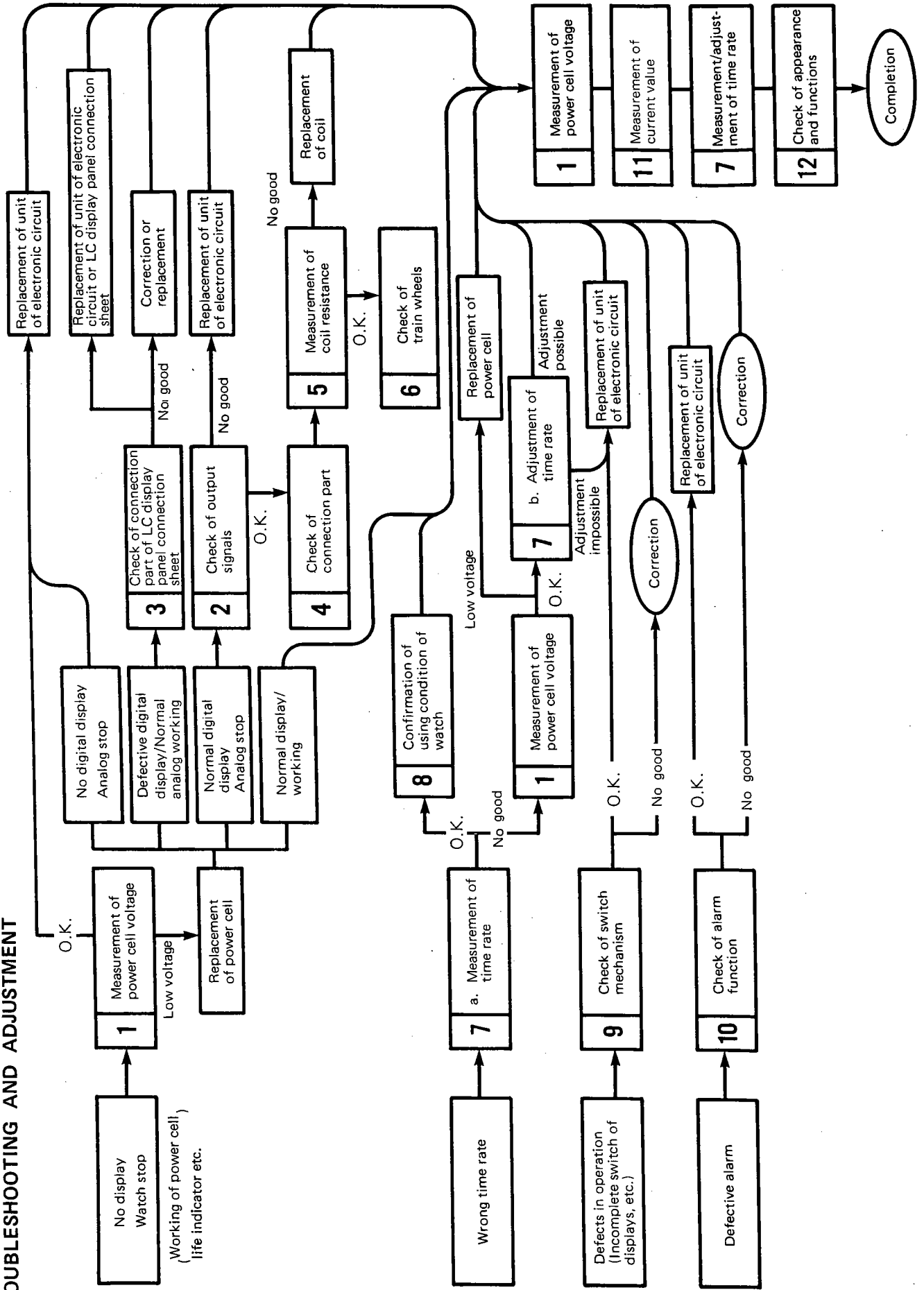

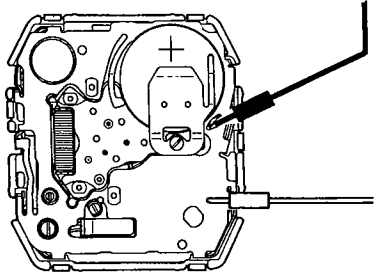
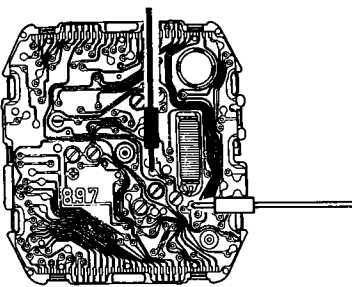
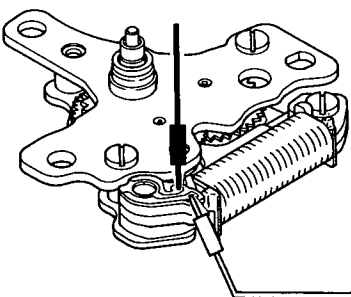
Items to be checked	How to check	Test results and repair procedure
(1) Measurement of power cell voltage	<p>* Refer to the basic manual II-1-a for tester setting.</p> 	<p>Over 1.5V → Nondefective</p> <p>Under 1.5V → Replace power cell</p>
(2) Check of output signal	<p>* Refer to the basic manual II-1-b for tester setting.</p> 	<p>Tester pointer swings right and left every 20 sec. — Nondefective</p> <p>No output signal — Replace electronic circuit unit</p>
(3) Check the connection parts of the LC display panel, connection sheet	Refer to the basic manual II-2-a.	
(4) Check of connection parts	Refer to the basic manual II-2-a.	
(5) Measurement of coil resistance	<p>* Refer to the basic manual II-1-c for tester setting.</p> 	<p>Under <math>1.2k\Omega \sim 1.6k\Omega</math> → Nondefective</p> <p>Resistance value outside the above range → Replace the coil unit</p>
(6) Check of connection parts	Refer to the basic manual II-2-b.	
(7) Measurement and adjustment of the time rate	<ul style="list-style-type: none"> <li>● CQT-101 Digital — Measurement is possible in any range Analog — 60 sec. range</li> <li>● CQT-210 Digital — Measurement is possible in any range Analog — Not possible</li> </ul>	<ul style="list-style-type: none"> <li>● Slight error → Adjust the trimmer condenser</li> <li>● If the adjustment cannot be made using the trimmer condenser → Replace the electronic circuit unit</li> </ul>

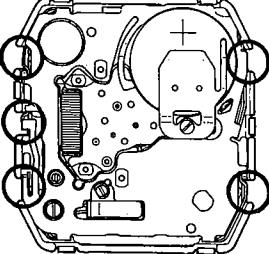
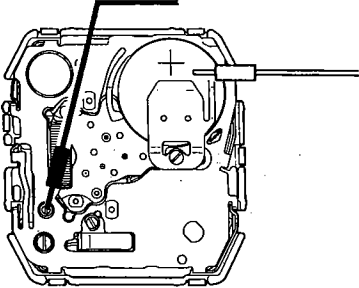
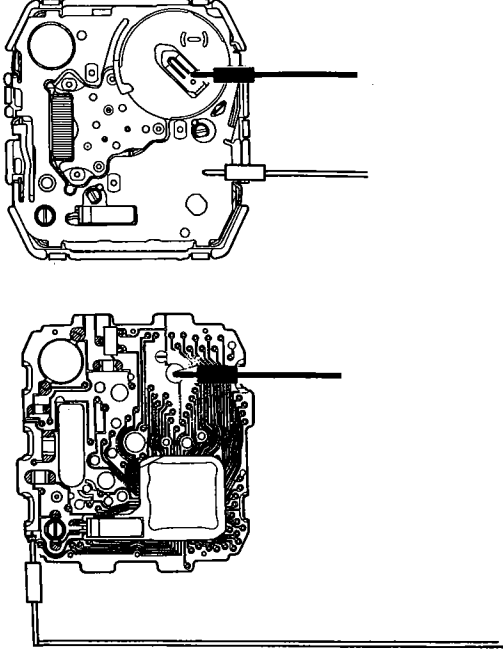
Items to be checked	How to check	Test results and repair procedure
(8) Confirmation using condition of the watch	Refer to the basic manual II-2-e.	
(9) Check of switch mechanism	<p>Make sure that the circled switch parts contact the electric circuit pattern.</p> 	Bad connection — Re-assemble or Replace the parts.
(10) Check of alarm function	<p>* Refer to the basic manual II-1-d for tester setting. Both (S) and (R) buttons are pressed simultaneously in the ordinary time display mode.</p> 	<p>Tester point swings → Nondefective</p> <p>No alarm output → Replace the electronic circuit unit</p>
(11) Measurement of current value	<p>* Refer to the basic manual II-1-f for tester setting.</p> 	<p>● Current value of the complete module Under <math>2.0\mu\text{A}</math> → Nondefective</p> <p>Over <math>2.0\mu\text{A}</math> → Measure the unit of electronic circuits singly</p> <p>● Current value of the unit of electronic circuit Under <math>1.5\mu\text{A}</math> → Nondefective</p> <p>Over <math>1.5\mu\text{A}</math> → Replace the unit of electronic circuit</p>
(12) Check of appearance and functions	Refer to the basic manual II-2-f.	

**CITIZEN WATCH CO., LTD.**  
Tokyo, Japan